

## TSA-SHA 840/1240

- + AUTOMATIC "NON-STOP" WINDING UNIT
- + PRODUCTION OF HANDLES BAGS (shoppers type)
- + BOTTOM SEALED BAGS (star-bags type)
- + WOUND ON PLASTIC OR CARDBOARD CORES
- + RIBOBINATORE AUTOMATICO "NON STOP"
- + PRODUZIONE DI SACCHI CON MANIGLIA (tipo shoppers)
- + SALDATURA DI FONDO O CON FONDO ROTONDO (tipo star bags)
- + AVVOLTI SU ANIMA DI CARTONE

PATENTED



Slit seal device  
Gruppo taglia e salda



Automatic aligners  
Allineatori automatici

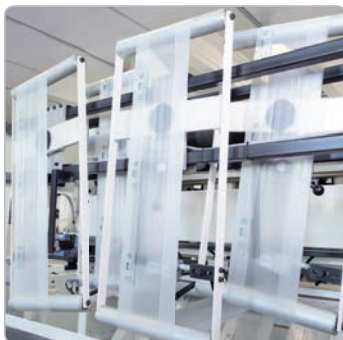

Star bag folding device  
Gruppo piegatore per sacchi a stella

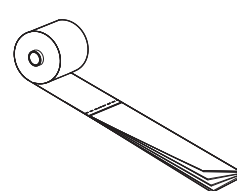
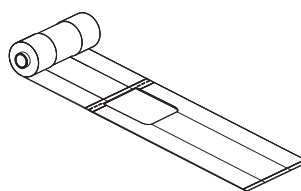
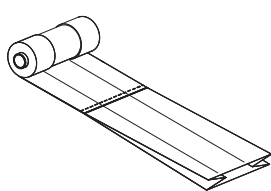
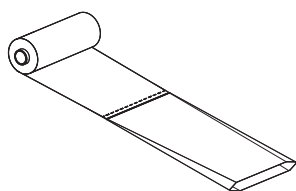
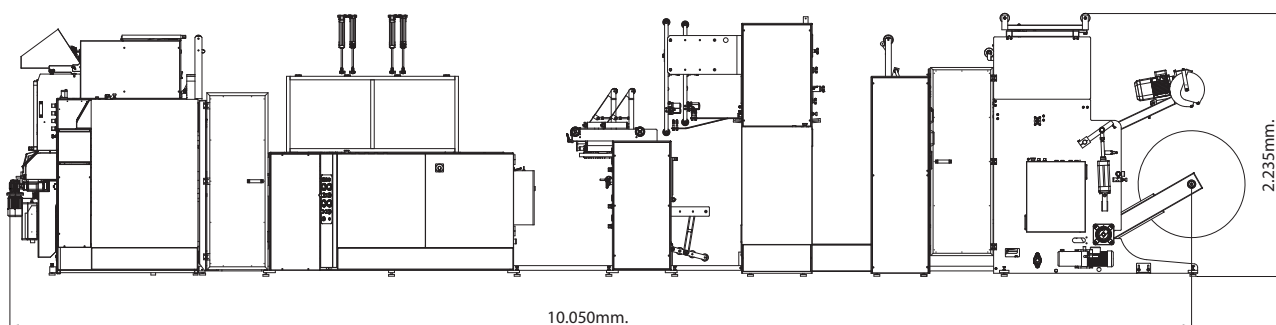
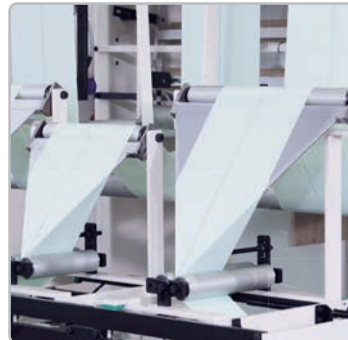

Technical data	Caratteristiche tecniche	Size   Formato 840	Size   Formato 1240
Mother roll maximum width	Massima larghezza bobina madre	1200 mm.	1640 mm.
Number of tracks	Numero piste	2 / 3	3 / 4
Material minimum thickness	Spessore minimo materiale	2 x 6 $\mu$	2 x 6 $\mu$
Material maximum thickness	Spessore massimo materiale	2 x 80 $\mu$	2 x 80 $\mu$
Minimum length	Lunghezza minima	50 mm.	50 mm.
Maximum length	Lunghezza massima	illimitata/unlimited	illimitata/unlimited
Maximum material speed (m. / min.)	Velocità massima (m. / min.)	150 (m. / min.)	150 (m. / min.)
Maximum cycling speed (strokes / min.)	Velocità massima (cicli / min.)	300	300
Plastic or cardboard core diameter	Diametro anima di cartone / plastica	30 standard	30 standard
Maximum rolls diameter	Diametro massimo rotoli	240 mm.	240 mm.



Our machines are ready for the processing of biodegradable plastics (EN 13432)  
Tutte le nostre macchine sono previste per la lavorazione di materiali biodegradabili (EN 13432)